

YTG15TLV-O

(12.5 kVA / 3-Phase / TNV Series)

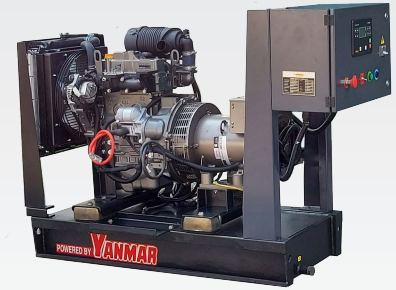

Open Type Dimension (mm)

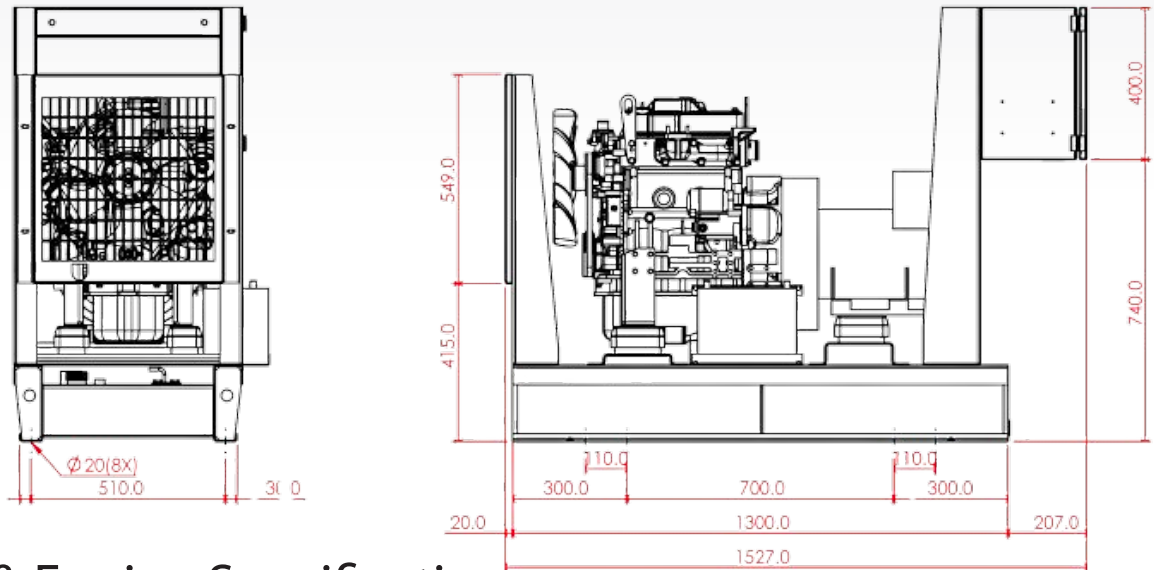

Genset & Engine Specification

AC Generator Model			YTG15TLV-O	
Output rating (kVA)	50 Hz	380V	Prime	12.5
			Standby	13.7
	60 Hz	440V	Prime	13
			Standby	14.5
Rated current (A)	50 Hz	Prime		19.0
			Standby	20.8
	60 Hz	Prime		17.1
			Standby	19.0
Rated frequency / rated speed	50 Hz	1500 RPM		
	60 Hz	1800 RPM		
No. of poles	4 poles			
Phase and wire	3-Phase 4-Wires			
Power factor	0.8			
Voltage regulation	Within +/- 1.5 %			
Excitation	Brushless, Rotating Exciter (with AVR)			
Insulation	Class 'H'			
Approx dry weight (silent)	kg	703		
Sound Level dBA from 1 meter / 7 meter	dBA	73 / 63		
Approx dry weight (open)	kg	621		

Engine Model		3TNV88-GGE
Type of combustion chamber		Direct Injection
Air intake system		Natural Aspiration
Output rating (HP)	1500 RPM (50 Hz)	12.3
	1800 RPM (60 Hz)	14.8
Rated speed (50/60 Hz, rpm)		1500 / 1800
Bore (mm) x stroke (mm)		88 x 90
Piston displacement (cm ³)		1642
No. of cylinders		3
Fuel		Diesel Fuel ASTM 2D
Fuel consumption (L/hr) at 50/60 Hz	75% load	2.69/3.24
	100% load	3.59/4.32
Lubricating oil capacity (L)		6.7
Coolant capacity (L)		2.0
Fuel tank capacity (L)	sound proof	130
	open skid	70
Starting motor (v-kW)		12 - 1.2
Charging generator (V-A)		12 - 40
Battery capacity (V-Ah)		12 - 65 x 1
Starting system		Electric Starting Motor
Cooling system		Radiator with fan
Lubricating system		Forced lubrication with trochoid pump

POWERED BY :

