

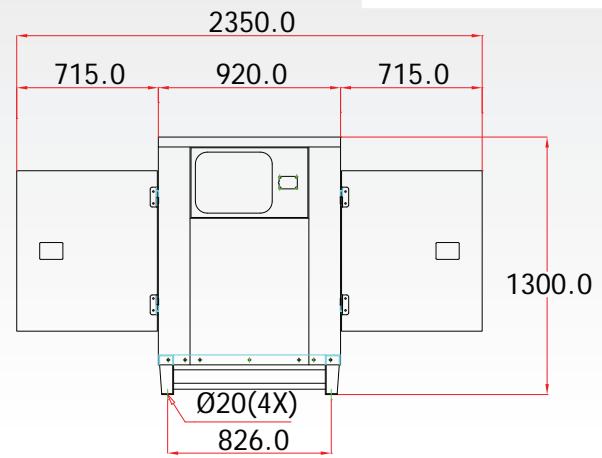

YTG65TLV (50 kVA)

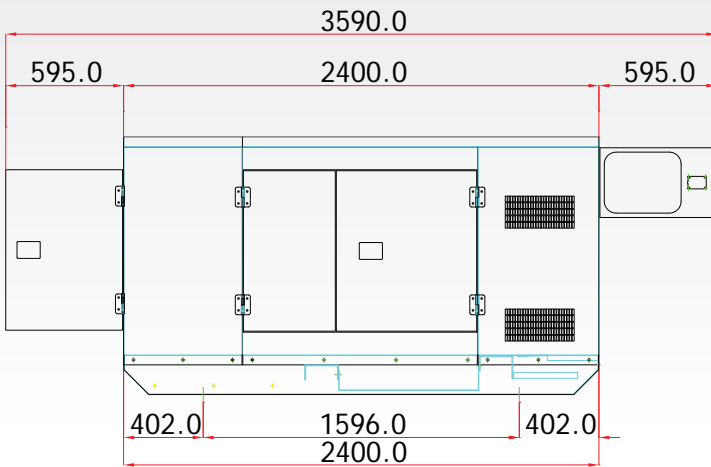

Silent Type Dimension (mm)



Open Type Dimension (mm)

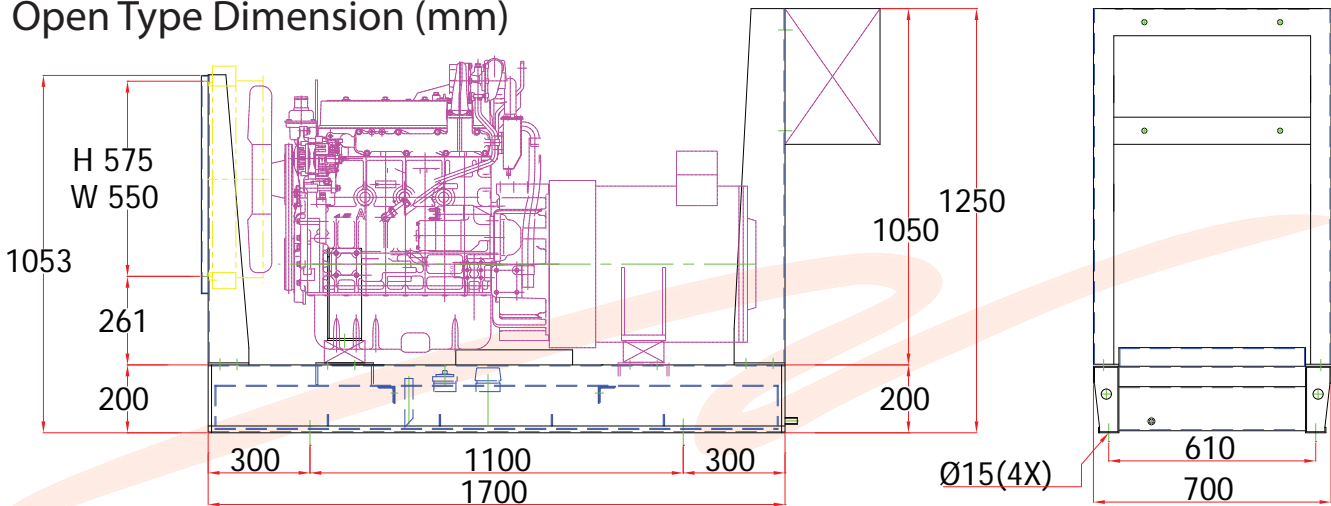

Genset & Engine Specification



AC Generator Model			YTG65TLV	
Output rating (kVA)	50 Hz	380V	Prime	50.0
			Standby	55.0
	60 Hz	440V	Prime	60.0
			Standby	65.0
Rated current (A)	50 Hz	Prime	76.0	
			Standby	83.6
	60 Hz	Prime		78.7
			Standby	85.3
Rated frequency / rated speed		50 Hz		1500 RPM
		60 Hz	1800 RPM	
No. of poles		4 poles		
Phase and wire		3-phase / 4 wires		
Power factor		0.8 (lagging)		
Voltage regulation		Within +/- 1.5 %		
Excitation		Brushless, Rotating Exciter (with AVR)		
Insulation		Class 'F' / 'H'		
Approx dry weight (silent)		kg	1362	
Sound Level dBA from 1 meter / 7 meter		dBA	78 / 68	
Approx dry weight (open)		kg	1045	

Engine Model		4TNV106	
Type of combustion chamber		Direct Injected	
Air intake system		NA	
Output rating (HP)	1500 RPM (50 Hz)	61	
	1800 RPM (60 Hz)	72.5	
Rated speed (50/60 Hz, rpm)		1500 / 1800	
Bore (mm) x stroke (mm)		106 x 125	
Piston displacement (cm ³)		4412	
No. of cylinders		4	
Fuel		Diesel Fuel ASTM 2D	
Fuel consumption (L/hr) at 100% load	50 Hz	11.5	
	60 Hz	13.9	
Lubricating oil capacity (L)		14	
Coolant capacity (L)		6	
Fuel tank capacity (L)	sound proof	140	
	open skid	110	
Starting motor (v-kW)		12 - 3.0	
Charging generator (V-A)		12 - 60	
Battery capacity (V-Ah)		12 - 65 x 1	
Starting system		Electric Starting Motor	
Cooling system		Radiator with fan	
Lubricating system		Forced lubrication with trochoid pump	

POWERED BY :

