

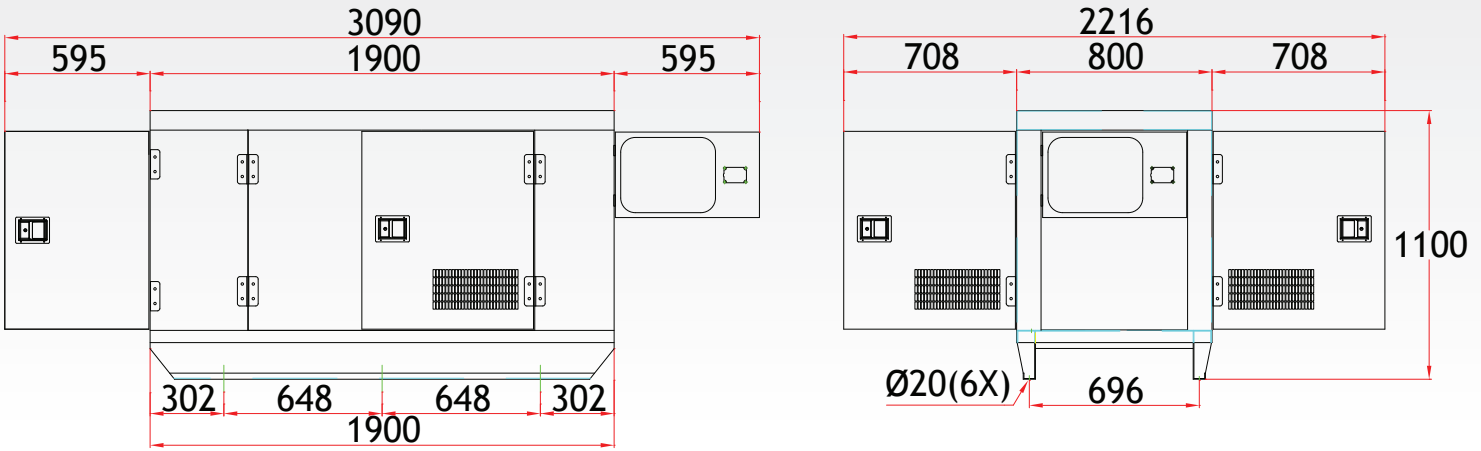

Silent Type Dimension (mm)

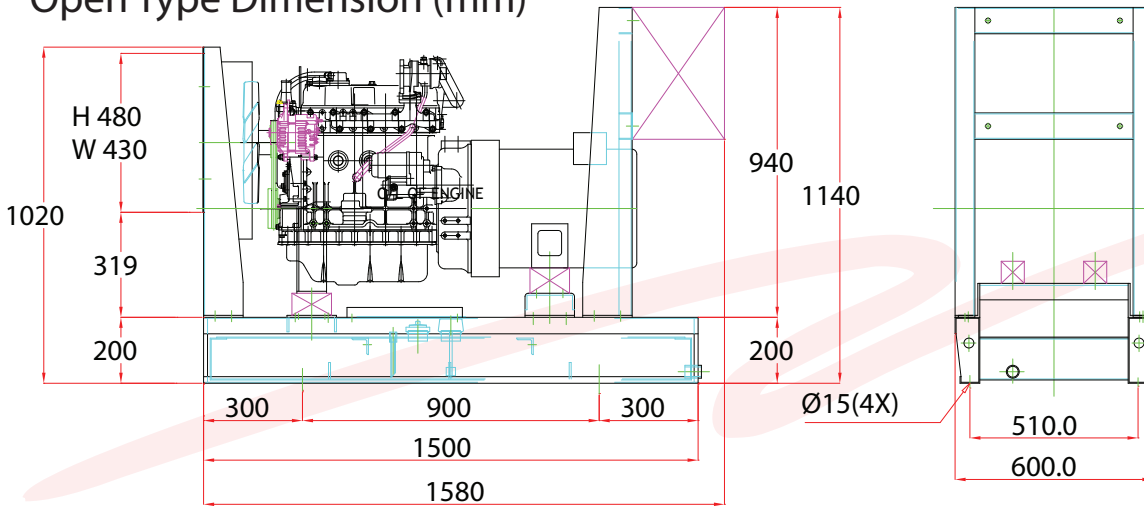

Open Type Dimension (mm)



Genset & Engine Specification



AC Generator Model			YTG30TLV	
Output rating (kVA)	50 Hz	380V	Prime	20.0
			Standby	22.0
	60 Hz	440V	Prime	25.0
			Standby	27.5
Rated current (A)	50 Hz	Prime		30.4
			Standby	33.4
	60 Hz	Prime		32.8
			Standby	36.1
Rated frequency / rated speed	50 Hz	1500 RPM		
	60 Hz	1800 RPM		
No. of poles	4 poles			
Phase and wire	3-phase / 4 wires			
Power factor	0.8 (lagging)			
Voltage regulation	Within +/- 1.5 %			
Excitation	Brushless, Rotating Exciter (with AVR)			
Insulation	Class 'F'			
Approx dry weight (silent)	kg	817		
Sound Level dBA from 1 meter / 7 meter	dBA	73 / 63		
Approx dry weight (open)	kg	708		

Engine Model		4TNV84T
Type of combustion chamber		Direct Injected
Air intake system		Turbo Charged
Output rating (kW)	1500 RPM (50 Hz)	19.1
	1800 RPM (60 Hz)	24.3
Rated speed (50/60 Hz, rpm)		1500 / 1800
Bore (mm) x stroke (mm)		84 x 90
Piston displacement (cm ³)		1995
No. of cylinders		4
Fuel		Diesel Fuel ASTM 2D
Fuel consumption (L/hr) at 100% load	50 Hz	5.57
	60 Hz	6.8
Lubricating oil capacity (L)		7.4
Coolant capacity (L)		2.7
Fuel tank capacity (L)	sound proof	55
	open skid	85
Starting motor (v-kW)		12 - 1.4
Charging generator (V-A)		12 - 40
Battery capacity (V-Ah)		12 - 65 x 1
Starting system		Electric Starting Motor
Cooling system		Radiator with fan
Lubricating system		Forced lubrication with trochoid pump

POWERED BY :

